

RCFF

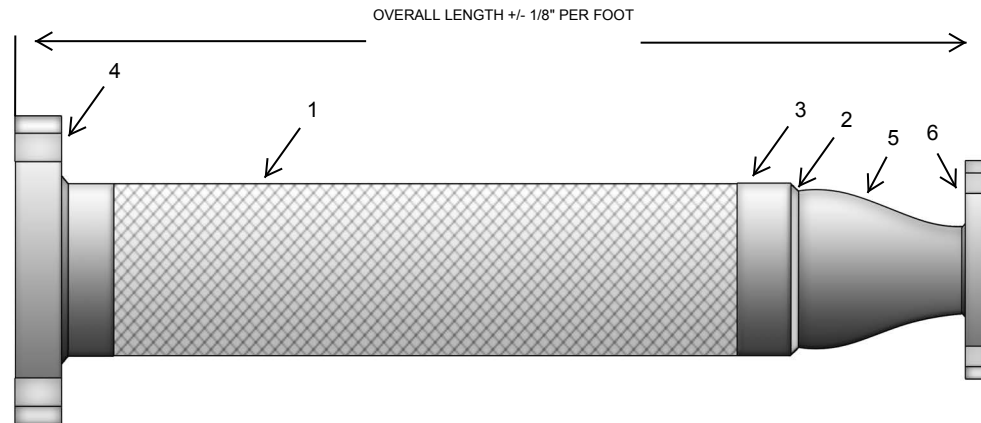

MATERIALS

- #1 HOSE & BRAID: STAINLESS STEEL HOSE WITH 1-LAYER OF STAINLESS STEEL BRAID
- #2, #3 BRAID COLLAR: STAINLESS STEEL HELI-ARC WELD/ MIG WELD
STAINLESS STEEL BRAID COLLAR
- #4, #6 END FITTINGS: CARBON STEEL PLATE FLANGE-FLAT FACE 150#
CARBON STEEL PLATE FLANGE-FLAT FACE 150#
- #5 REDUCER: SCH. 40 CARBON STEEL CONCENTRIC WELD REDUCER
*12" ID AND LARGER ARE SCHEDULE STANDARD (STD)



Note: Standard port size offering 1/4", 1/2", 3/4" and 1" will increase overall length by 2"

QTY	MODEL NUMBER	DESCRIPTION	WRK. PSI	@ TEMP.	LATERAL OFFSET	LARGE END SIZE	SMALL END SIZE	WT. LBS.
	RCFF1210	*12" X 10" X 20" OAL REDUCER	160	70° F	3/16"	12"	10"	145
	RCFF1008	10" X 8" X 18" OAL REDUCER	175	70° F	3/16"	10"	8"	90
	RCFF1006	10" X 6" X 18" OAL REDUCER	175	70° F	3/16"	10"	6"	90
	RCFF0806	8" X 6" X 18" OAL REDUCER	220	70° F	1/4"	8"	6"	67
	RCFF0805	8" X 5" X 18" OAL REDUCER	220	70° F	1/4"	8"	5"	67
	RCFF0804	8" X 4" X 18" OAL REDUCER	220	70° F	1/4"	8"	4"	65
	RCFF0605	6" X 5" X 17" OAL REDUCER	165	70° F	3/8"	6"	5"	40
	RCFF0604	6" X 4" X 17" OAL REDUCER	165	70° F	3/8"	6"	4"	40
	RCFF0603	6" X 3" X 17" OAL REDUCER	165	70° F	3/8"	6"	3"	38
	RCFF0504	5" X 4" X 16" OAL REDUCER	167	70° F	3/8"	5"	4"	25
	RCFF0503	5" X 3" X 16" OAL REDUCER	167	70° F	3/8"	5"	3"	25
	RCFF0525	5" X 2-1/2" X 16" OAL REDUCER	167	70° F	3/8"	5"	2 1/2"	23
	RCFF0403	4" X 3" X 13" OAL REDUCER	210	70° F	3/8"	4"	3"	16
	RCFF0425	4" X 2-1/2" X 13" OAL REDUCER	210	70° F	3/8"	4"	2 1/2"	16
	RCFF0402	4" X 2" X 13" OAL REDUCER	210	70° F	3/8"	4"	2"	16
	RCFF0325	3" X 2-1/2" X 13" OAL REDUCER	250	70° F	3/8"	3"	2 1/2"	15
	RCFF0302	3" X 2" X 13" OAL REDUCER	250	70° F	3/8"	3"	2"	15
	RCFF0315	3" X 1-1/2" X 13" OAL REDUCER	250	70° F	3/8"	3"	1 1/2"	15
	RCFF2502	2-1/2" X 2" X 13" OAL REDUCER	390	70° F	3/8"	2 1/2"	2"	14
	RCFF2515	2-1/2" X 1-1/2" X 13" OAL REDUCER	390	70° F	3/8"	2 1/2"	1 1/2"	14

TEMPERATURE DERATING FACTORS: MULTIPLY X WRK. PSIG

200° F	250° F	300° F	350° F	400° F	500° F	600° F	700° F	800° F	900° F
0.94	0.92	0.88	0.86	0.83	0.78	0.74	0.7	0.66	0.62

DRAWN BY:

DRAWING NUMBER:

REV:

SIGNATURE:

DATE:

PO NUMBER:

PROJECT:

CUSTOMER:

NOTES: