

T5 PTFE EXPANSION JOINT

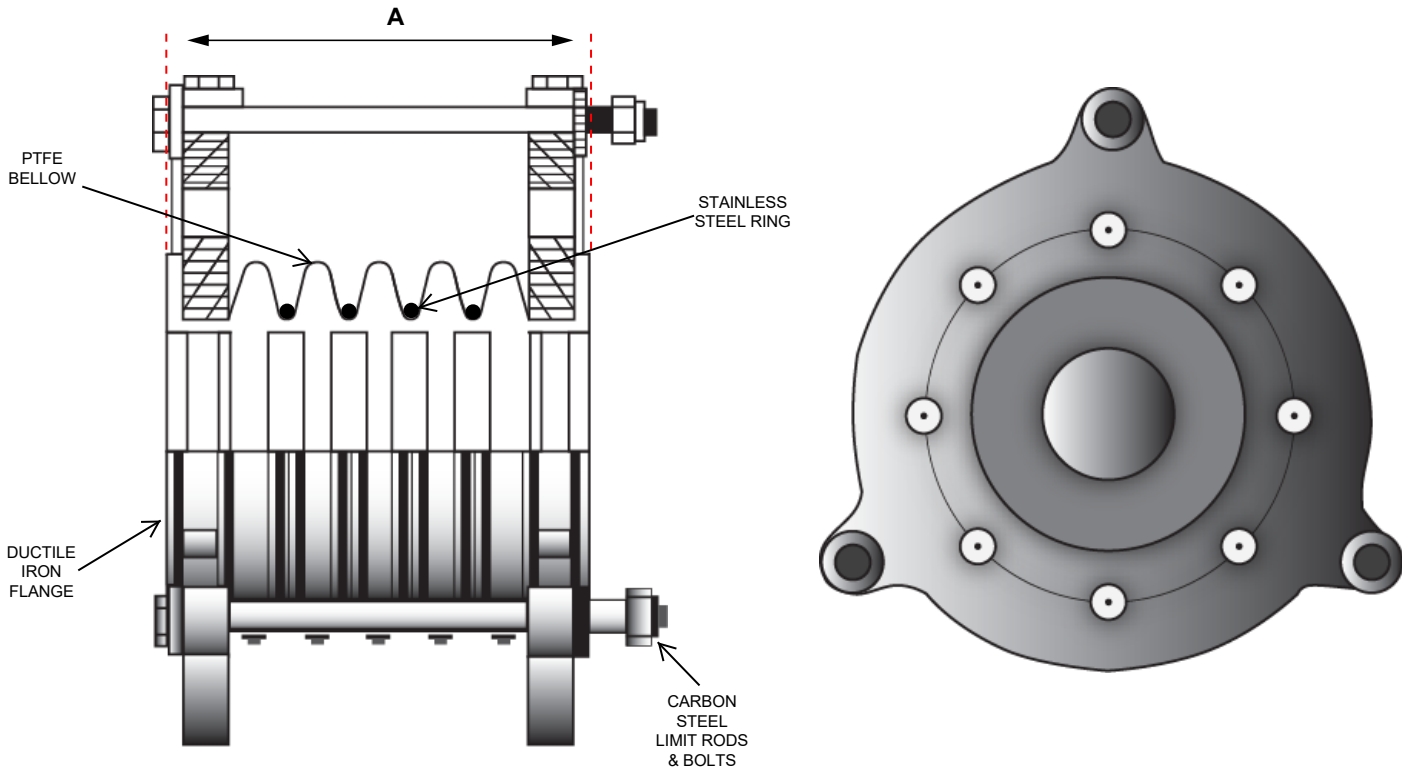

NOTE: FOR PROPER OPERATION ALL PIPING MUST BE PROPERLY ANCHORED AND GUIDED

| QTY | I.D. | MODEL NUMBER | "A" OAL | AXIAL MOVEMENT | LATERAL MOVEMENT | ANGULAR DEFLECTION | PSIG @ 70°F | WT. LBS. |
|-----|------|--------------|---------|----------------|------------------|--------------------|-------------|----------|
| | 1 | T5-100 | 3 | 0.5 | 0.5 | 20° | 72 | 2 |
| | 1.5 | T5-150 | 3.5 | 0.75 | 0.5 | 20° | 72 | 5 |
| | 2 | T5-200 | 4 | 1 | 0.5 | 20° | 72 | 9 |
| | 3 | T5-300 | 5 | 1 | 0.5 | 20° | 72 | 14 |
| | 4 | T5-400 | 5.25 | 1.25 | 0.625 | 20° | 72 | 20 |
| | 6 | T5-600 | 6 | 1.25 | 0.625 | 20° | 72 | 31 |
| | 8 | T5-800 | 8 | 1.25 | 0.625 | 20° | 48 | 50 |

DRAWN BY:

DRAWING NUMBER:

REV:

SIGNATURE:

DATE:

PO NUMBER:

PROJECT:

CUSTOMER:

NOTES: